

Product Description

Accessory type Press-fitting for plumbing and heating.

Easypress accessories are specifically designed for attachment to cross-linked polyethylene PEX-a and PEX-b pipes, through compression bonding technique or pressfitting system. The radial compression fixed sleeves are made of stainless steel and are subject to the fitting body by a plastic ring.

General view of fitting Easypress

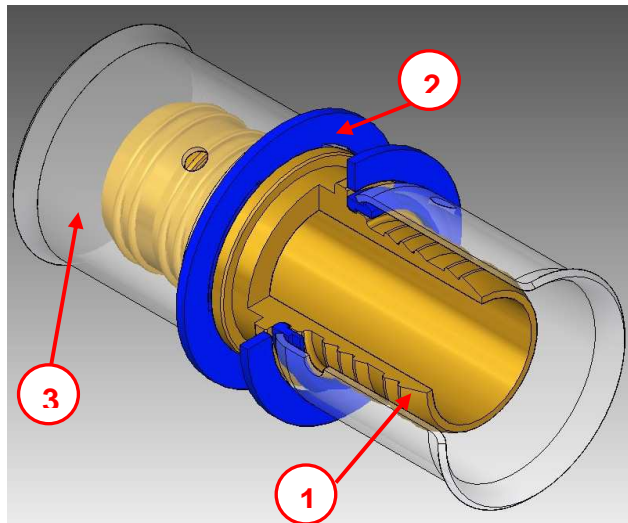

List of Components

Order No.	Name	Material	Manufacturing process
1	Brass body	CW617N	Machining / stamping
2	Plastic ring	AMCEL KP20	Injection mold
3	SS ring	Stainless Steel AISI 304	Cut and welding

Color of plastic ring

Color	Size of the fitting					
	12	16	16x1,8	20	25	32
Blue	•	•		•	•	•
Green			•			

Brass material specification

Material	Composition					
	Cu	Al	Fe	Ni	Pb	Sn
Brass CW617N	57,0 – 59,0	max .0,05	max. 0,30	*max. 0,1	*1,6 – 2,2	max. 0,30

* low lead and nickel content according European Directive 98/83 / CE and German standard DIN 50930

Advantages of fittings Easypress of BLANSOL

- **Increased resistance to tensile stresses**
The geometry of the SS ring allows the positioning of the clamping jaw with respect to the shape of the fitting, which improves its resistance to tensile stress.
- **No timeouts**
This system requires no waiting once made the union with allowing installation into service immediately.
- **Guarantee seal**
Easypress fitting meets the most stringent European regulations which guarantees the tightness and sanitary qualities.
- **Brass with low lead**
The brass alloy used in Easypress fittings contains a low lead content, so that it meets the most stringent European regulations concerning materials in contact with drinking water (European Directive 98/83 / CE and German standard DIN 50930).
- **Stainless steel rings welded**
Stainless steel rings are made from welded strip. This process gives to the SS rings smaller hardness than those manufactured by stamping, so that the posterior tightening of the SS rings can be done with less effort of the tool. Also, the thickness of the SS rings remains constant

Easypress fittings are compatible with jaws RF, U and H.

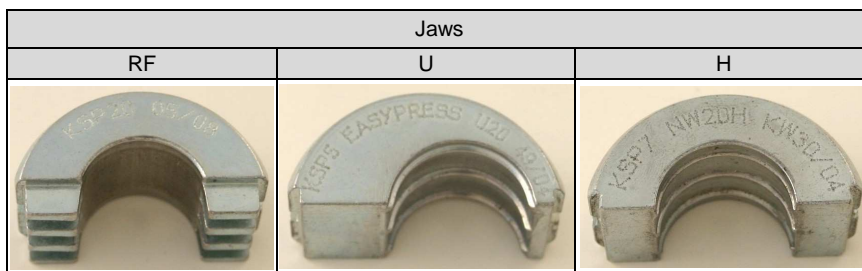

Assembly instructions

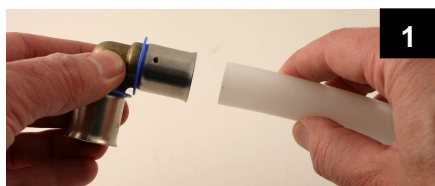

1

01. Assembly
Insert the pipe into the SS ring



2

02. Check
Make sure the pipe is visible through the hole of SS ring



3

03. Press
Pressing the unión



PRODUCT TECHNICAL SPECIFICATION FITTINGS EASYPRESS

Rev.: 2

Page 3 de 3

Range of fittings

Range of fittings Easypress: 12, 16, 20, 25 and 32.

Recommendations

- Cut the pipe with suitable scissors making sure the cut is clean
- Use only Barbi pipes PEX-a / PEX-b

Certifications

Easypress fittings has been designed and manufactured under the requirements specified in the UNE EN ISO 15875. The Easypress fittings have the Product Certificate issued by AENOR (Spanish standard).



Labeled

Labeling example of box:

Includes piece reference, the description of the product (5 languages), size, bar-code, units per box, traceability (WYYW) and certifications.

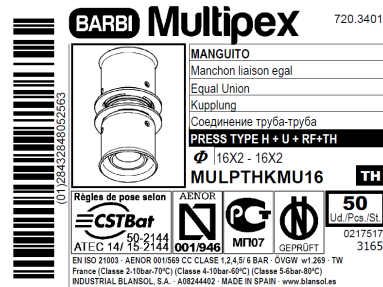

Example of individual bag labeling:

Includes piece reference, the description of the product (5 languages), size, bar-code, traceability (WYYW) and manufacturer's data.

EasyPress

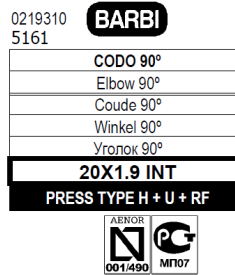

INDUSTRIAL BLANSOL, S.A. - MADE IN SPAIN

EASYAIKC20



Warranty Barbi

Cross-linked polyethylene pipes and brass fittings for the connection system Easypress, are guaranteed for a maximum amount of 1,5 million euros, for 15 years, for damages caused by defects in the product design or manufacturing default.

